

TELEDYNE ANALYTICAL INSTRUMENTS

Trace and Percent Oxygen Transmitter



InstaTrans

Teledyne has redefined the ease and simplicity of detecting either ppm or percent levels of oxygen in a process with a single device – the INSTA TRANS™ O2 transmitter. By applying lessons learned from our Series 300T & 300P intrinsically safe oxygen transmitter designs introduced in the late 1980s, and adding parameters required by today's users, the Insta Trans offers unprecedented:

- Flexibility
- Ease of use
- Quick recovery on ppm O2 applications (when changing out sensors)
- Reliability
- Cost effectiveness

FLEXIBILITY

The Insta Trans is a two-wire, loop-powered 4-20 mA oxygen transmitter packaged within a weather tight NEMA-4 housing. The product was named for its built-in level of flexibility. It can instantly transform from ppm to percent (or vice-versa) simply by changing out the Teledyne sensor and resetting the range scale of the unit to ppm or percent via the function keypad.

The operator can ensure proper changes have been made via the range indication continuously shown on the built-in meter. That's it. No other electrical or resistor changes are required. By building this flexibility into the product Teledyne allows users the ability to conveniently move the Insta Trans from one point in the plant to another to tackle a variety of applications as required.

The Insta Trans has six user selectable ranges from 0-10 ppm to 0-25 %. The user can easily change to the preferred range via the built in function keypad. In addition, depending on the corrosive nature of the sample, the Insta Trans can be supplied with either stainless steel or nylon wetted parts.

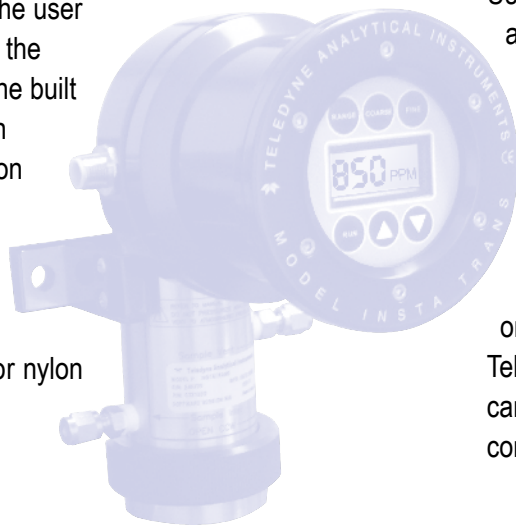

EASE OF USE

Unlike the competition, Teledyne's transmitter offers one key feature invaluable to the user – a built-in meter. Through visual feedback, the user confirms correct operation of the Insta Trans whether it be a range change or conducting a span calibration. The meter incorporates various readouts to clearly and continuously show:

- Oxygen concentration indication
- Range indication
- Function indication

Utilizing six function keypads for range selection and calibration, the user can easily operate the Insta Trans without continuously referring to an instruction manual. The UV and EMI resistant keypad provides tactile feedback and control functions which are intuitive and easily mastered.

INSTA TRACE INSIDE

Teledyne is the inventor of the Micro-fuel Cell oxygen sensor and has developed and perfected the use of electrochemical oxygen sensors for a wide variety of applications.

For the Insta Trans, Teledyne patented a novel method of dramatically improving the time it takes a plant operator to obtain meaningful results (below 10 ppm O2) when changing from an expired cell to a new one.

Historically, the recovery period required when changing out trace Micro-fuel Cells was anywhere from 12 to 24 hours. Under Teledyne's newly patented sensing technology, INSTA TRACE™, users can obtain meaningful trace oxygen results in just a few minutes.

Using the Insta Trace sensing technology, users are now able to get back on line quickly, and reliably analyze their process stream to ensure compliance with manufacturing guidelines. The Insta Trace oxygen sensing technology saves both time and money.

In addition to the benefits derived from a quicker recovery, Teledyne assures quality through 100% in-house testing on trace oxygen sensors ensuring that only the most reliable sensors are supplied to the field. Teledyne offers the market a wide range of sensors that can be applied in a variety of different process stream conditions.

INTRINSICALLY SAFE DESIGN

The Insta Trans can be used in a general purpose, non-hazardous environment or a hazardous area. When used in Division 1 or equivalent hazardous / classified locations, the Insta Trans must be installed in conjunction with optional intrinsic safety barriers. The Insta Trans is designed as intrinsically safe for use in Class I, Division 1, Groups A, B, C, & D hazardous areas or EExiallCT4 (60°C), and certified by Factory Mutual and BASEEFA.

The Insta Trans is self-certified by Teledyne as suitable for Class I, Division 2 areas without the use of I/S barriers utilizing specific installation guidelines.

FEATURES

- Built-in digital display
- Simple intuitive controls
- Easy field calibration and range selection
- SS or nylon wetted parts
- Weather tight NEMA-4 construction
- Hermetically sealed for direct installation in the field without any added protection
- Reverse voltage protection and temp compensation
- Digital electronic control circuitry with permanent SPAN setting memory

OPTIONS

- Insta Trace oxygen sensor (ppm applications)
- Intrinsically safe operation

APPLICATIONS

- Petrochemical process control
- Natural gas transmission
- Chemical feedstock purity analysis
- Air separation & liquefaction processes
- Inert gas generator product analysis
- Heat treating and bright annealing
- Gas purity certification
- Nuclear fuel processing
- Quality assurance
- Flue gas analysis
- And many other applications



Insta Trans O2 Transmitter for trace O2 detection in petrochemical applications

VALUE ADDITION / TELEDYNE EXPERTISE

Teledyne maintains in-house capability to both design and manufacture a wide variety of sample systems tailored to meet our customers' process requirements. We design sample-conditioning systems for our complete line of process analyzers and welcome the opportunity to provide a cost-effective, integrated system with the Insta Trans specific to your needs. Please contact one of our local sales outlets or Teledyne directly for details.

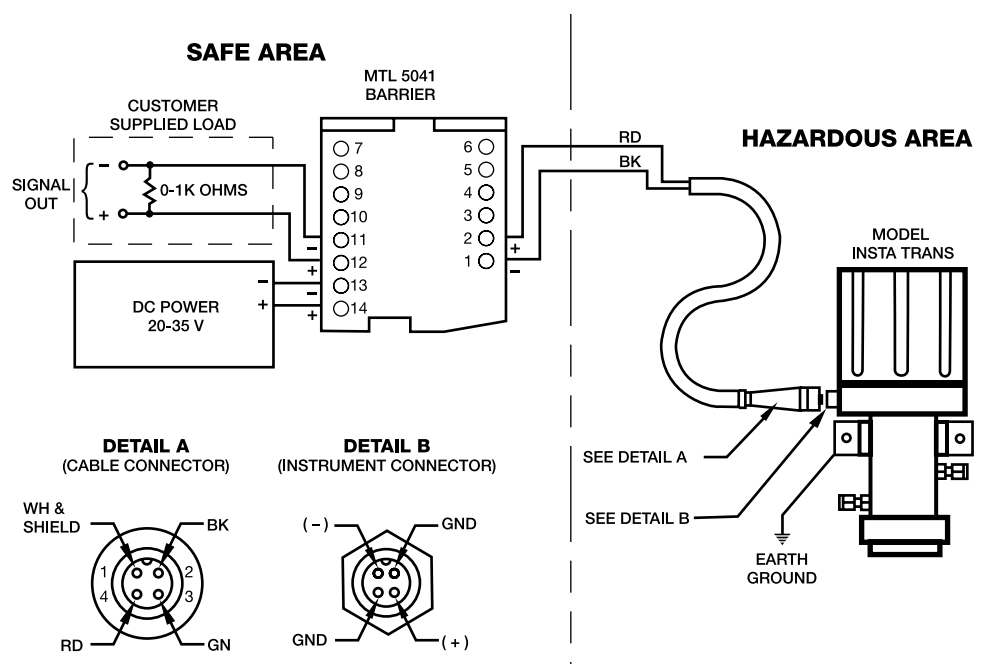

InstaTrans Oxygen Transmitter

SPECIFICATIONS

Ranges:	Trace — 0-10, 0-100, 0-1000 ppm Percent — 0-1, 0-10, 0-25%
Outputs:	% of range; 4-20 mA DC non-isolated (power loop)
Wetted parts:	316 stainless steel, viton o-ring, gold and nylon contact plate
Accuracy:	±1% of full scale for all ranges at constant temperature
Enclosure:	NEMA 4 rated stainless steel and aluminum
Operating temp:	32 – 122°F (0 – 50°C)
Response time:	(10 – 90% @ 1.8 SPLM @ 24°C with B2C sensor) < 40 seconds on 0-10 ppm range < 15 seconds on 0-100 ppm range

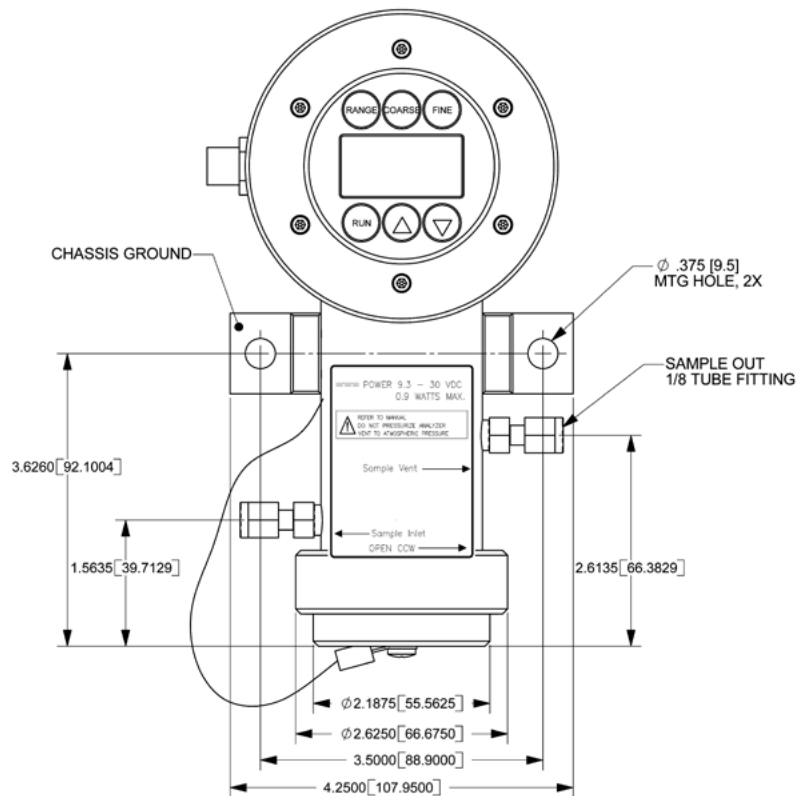
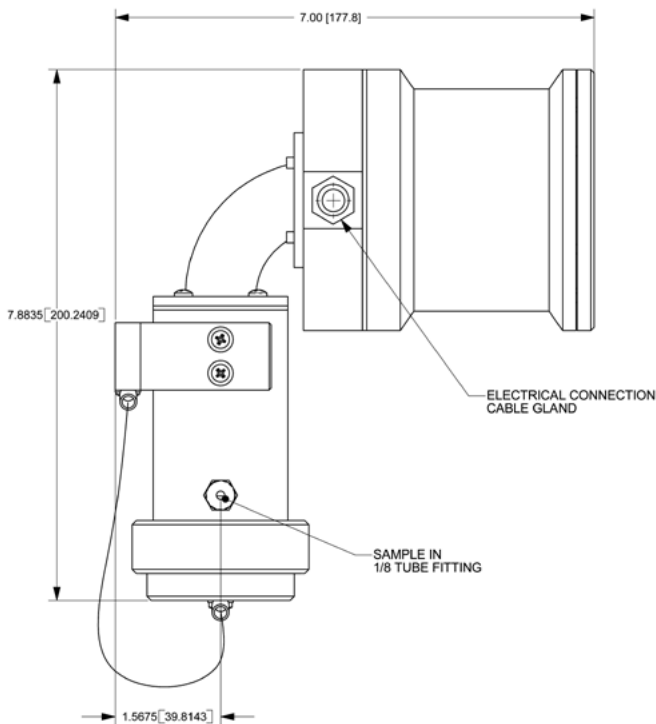

Gas connections:	1/8" stainless steel tube
Sensor type:	B2C, B1, A2C, L2C, and the new Insta Trace
Voltage requirements:	9.3 – 30 vDC
Weight:	7.04 lb (3.20 Kg)
LCD panel meter:	3.5 digit display
Panel indicators:	PPM, %, RUN, FIN, and COR; ppm or percent oxygen range; fine and coarse span adjustment
Customer interface:	6 button membrane — Run, Range, Coarse, Fine, Arrow Up, Arrow Down
Approvals:	CE, Factory Mutual for Class I, Division 1 and BASEEFA for EExialICT4

TELEDYNE ANALYTICAL INSTRUMENTS

A Teledyne Technologies Company

16830 Chestnut Street
City of Industry, California 91748, USA

TEL: 626-934-1500 or 888-789-8168
FAX: 626-934-1651 EMAIL: ask_tai@teledyne.com

www.teledyne-ai.com

Warranty

Instrument is warranted for 1 year against defects in material or workmanship

NOTE: Specifications and features will vary with application. The above are established and validated during design, but are not to be construed as test criteria for every product. All specifications and features are subject to change without notice.

